

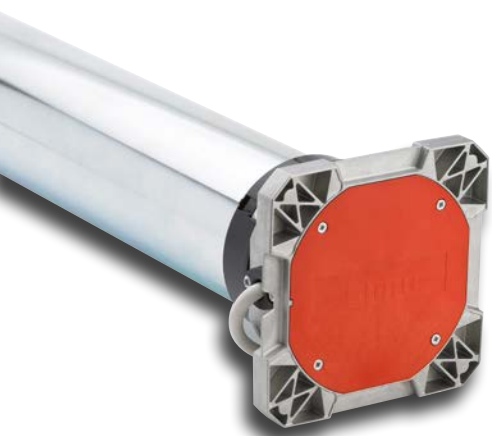

T8 S & T8 SDMI TUBULAR MOTORS

FOR COMMERCIAL AND INDUSTRIAL CLOSURES



INNOVATION AND TECHNOLOGY CONCENTRATED IN ONLY 43 MM!

- Very flexible installation process thanks to the adjustable support and the narrowest head on the market, only 43mm.
- Intuitive and secured manual override operation.
- Easy integration thanks to the standardization of components.
- Up to 300Nm, in single-phase current.

THE T8S MOTOR

MAKES INTEGRATION AND INSTALLATION EASIER

43 MM HEAD, THE NARROWEST ON THE MARKET

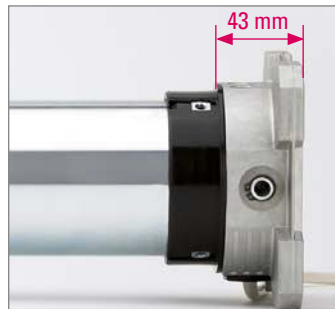

- For use on a standard 50mm post.
- Allows use of cased tracks, so no need to install a post.
- Identical dimensions, with or without manual override.
- Makes entrances more attractive with wider access.

MOTOR CAN BE INSTALLED IN ANY POSITION

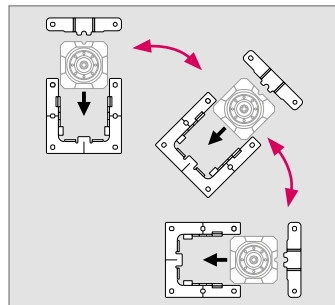
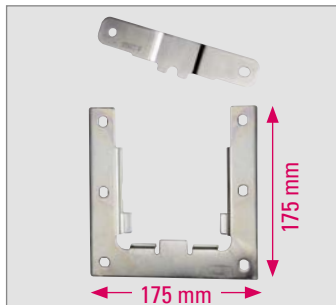

Adjustable support.

- Shaft inserted from the top or in the front
- 4 installation positions with the square head
- Motor can be angled up to 45°
- Practical fixing of the support
- Tolerates misalignment in installation, and gives freedom of movement to the motorised shaft.

EASY ACCESS TO LIMIT STOP ADJUSTMENT

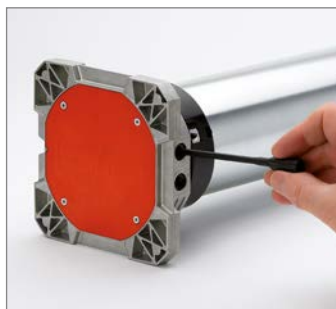

- Whatever the position of the head of the motor.
- Conical-tip adjustment screw, for easy insertion of the clippable adjusting tool supplied.

THE T8S MOTOR FITS ALL TYPES OF INSTALLATIONS

INSTALLATION BETWEEN WALLS

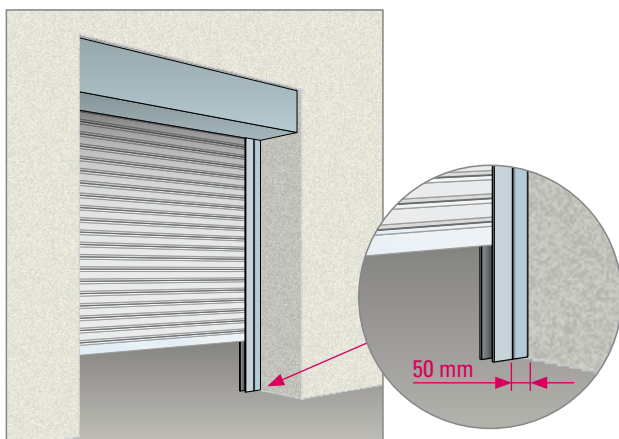

SURFACE-MOUNTED INSTALLATION

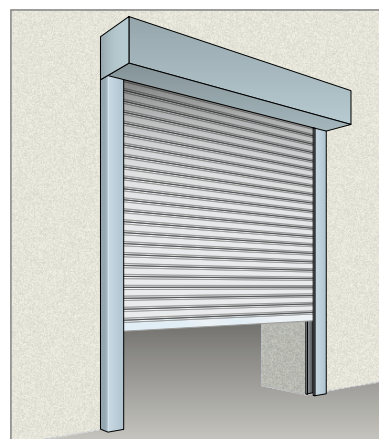

A MANUAL OVERRIDE SYSTEM

UNIQUE ON THE MARKET

CROSSPIECE MANUAL OVERRIDE WITH DIRECT DRIVE

No need to pull or push.

- Allows use of roller shutters accessories (7mm hexagonal or 6mm square).
- No recutting to the length of the accessory rod.
- Allows use of angle transmissions and other systems.

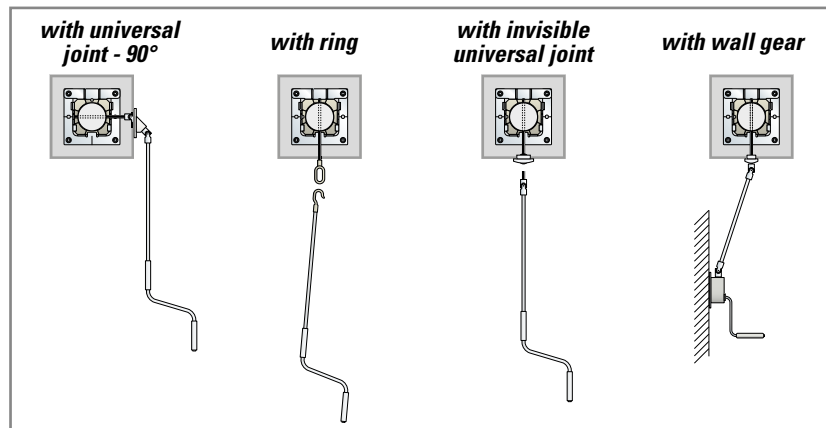

EASY AND QUICK TO OPEN

- Intuitive manual override, no need to pull on the ring or the shaft.
- Automatic reset of manual override after use.
- The operation immediately reassures the user, with visible movement of the shutter as soon as the manual override is operated.

USER PROTECTION

- The torque limit protects the user, preventing the shutter from dropping when the manual override is actuated, in the event of a simultaneous jamming of the safety brake, and a power failure.



OPTIMIZED PACKAGING, A + BY SIMU

- Packaging adapted to individual needs: single units or in 10s.
- Cardboard packaging, no polystyrene, easy to recycle.
- Reusable packaging wedges to protect the motor heads during transport to the installation site.



DIMENSIONS

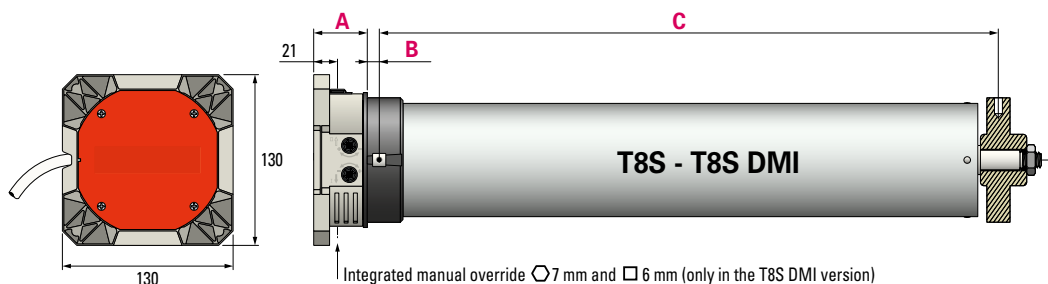

DESCRIPTION	MANUAL OVERRIDE		LENGTH A		LENGTH B		LENGTH C	
	WITHOUT	WITH						
T8S	x		43 mm*	49 mm**	8 mm*	18 mm**	609 mm*	595 mm**
T8S DMI		x	43 mm*	49 mm**	8 mm*	18 mm**	659 mm*	645 mm**

* Length with adaptor < 119 mm

** Length with adaptor ≥ 119 mm

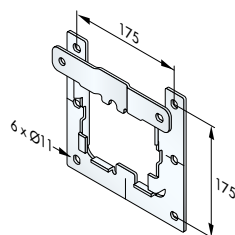

DESCRIPTION	REFERENCE
Bracket 175 x 175 mm	x 1 9018069 9018070

Bracket sold separately

RANGE

POWER SUPPLY 230V - 50 Hz



DESCRIPTION	TORQUE	SPEED	POWER	CURRENT	END-LIMIT CAPACITY	BASE DIAMETER	WEIGHT	REFERENCE	
								without safety end-limit	with safety end-limit
T8S 150	150 Nm	8 rpm	450 W	2 A	17 rounds	94 mm	9.5 kg	2008290	2008276
T8S 200	200 Nm	8 rpm	710 W	2.5 A	17 rounds	94 mm	11 kg	2008291	2008277
T8S 250	250 Nm	8 rpm	710 W	3.2 A	17 rounds	94 mm	11.5 kg	2008292	2008278
T8S 300	300 Nm	8 rpm	855 W	3.9 A	17 rounds	94 mm	12 kg	2008293	2008279
T8S DMI 150	150 Nm	8 rpm	450 W	2 A	17 rounds	94 mm	11 kg	2008304	2008280
T8S DMI 200	200 Nm	8 rpm	710 W	2.5 A	17 rounds	94 mm	12.5 kg	2008305	2008281
T8S DMI 250	250 Nm	8 rpm	710 W	3.2 A	17 rounds	94 mm	13 kg	2008306	2008282
T8S DMI 300	300 Nm	8 rpm	855 W	3.9 A	17 rounds	94 mm	13.5 kg	2008307	2008283

POWER SUPPLY 120V - 60 Hz



DESCRIPTION	TORQUE	SPEED	POWER	CURRENT	END-LIMIT CAPACITY	BASE DIAMETER	WEIGHT	REFERENCE
T8S 200	200 Nm	10 rpm	600 W	5,6 A	17 rounds	94 mm	11 kg	2008288
T8S 280	280 Nm	10 rpm	820 W	6,9 A	17 rounds	94 mm	12 kg	2008289
T8S DMI 200	200 Nm	10 rpm	600 W	5,6 A	17 rounds	94 mm	12,5 kg	2008302
T8S DMI 280	280 Nm	10 rpm	820 W	6,9 A	17 rounds	94 mm	13,5 kg	2008303





POWER SUPPLY 220V - 60 Hz

DESCRIPTION	TORQUE	SPEED	POWER	CURRENT	END-LIMIT CAPACITY	BASE DIAMETER	WEIGHT	REFERENCE
T8S 200	200 Nm	10 rpm	580 W	2,7 A	17 rounds	94 mm	13,72 kg	2008295
T8S DMI 200	200 Nm	10 rpm	580 W	2,7 A	17 rounds	94 mm	15,22 kg	2008309

SPECIFICATIONS

THERMAL CUT-OUT	4 minutes
T8S DMI REDUCTION RATIO	of the manual override: 190/1
PROTECTION INDEX	IP 44
AMBIENT WORKING TEMPERATURE	-10°C to +40°C and, exceptionally, -20°C to +60°C standard temperature range +5°C to +40°C
POWER CABLE 230V	2.5 metres (4x0.75mm ² wires, white H05 VVF)
POWER CABLE 220V	2.5 metres (4x0.75mm ² wires, grey H05 VVF)
POWER CABLE 120V	0.7 metres (4xAWG19 wires, white 05 VVF)
CYCLES PER DAY	10, non consecutive
WINDING TUBE	compatible with tubes from 100 x 2 mm

RECOMMENDED TYPES OF CONTROL

TYPE OF CONTROL	RADIO CONTROL	WIRED CONTROL WITHIN SIGHT, WITH MAINTAINED PUSH, WITHOUT SAFETY ACCESSORY
Operating mode	Automatic or sequential	Maintained push
Control boxes	 RSA-Hz PRO	not required
Control points	 Key switch and push buttons  Remote controls & radio transmitters	 Key switch or wired switch
Safety accessories	 Safety edge, photocell barrier & signalling light	not required

AN INNOVATION ...

THE RESULT OF 40 YEARS OF EXPERTISE!

In 1970, SIMU created its 1st model of the famous T8 range of motors for commercial and industrial closures.

Since then, these motors have been distributed all over the world and are renowned for their robustness and performance.

Today, the T8S and T8 SDMI are unique! They combine the historical performance and reliability of SIMU tubular motors with the design of a resolutely innovative motor head, very concentrated technology designed for professionals in the closure industry.

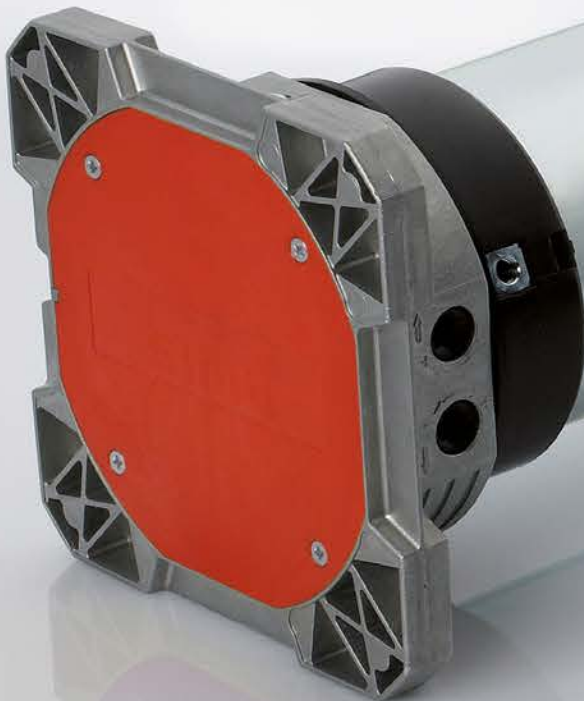



Present for more than 65 years on the market, SIMU has become the reference brand for manufacturers and assemblers of roller shutters.

- French manufacturer
- Inventor of the tubular motor
- More than 11 million motors installed all over the world
- 100% of motors tested

MOTOR WARRANTY
5 years

Realization SIMU - 03/19 - SIMU SAS, capital 5 000 000 euros, RCS Vesoul 425 650 090.
This document is not legally binding. We reserve ourselves the right to make any useful modification in order to constantly develop and improve our tender.
SIMU shall not be held responsible for misuse by non-professionals.



Visit our website: www.simu.com

-  E-catalogue
-  Manuals
-  Videos
-  Recommendations
-  FAQ

Visit our Youtube channel:  YouTube

